

Heat Mate™

KEROSENE HEATER OWNER'S MANUAL

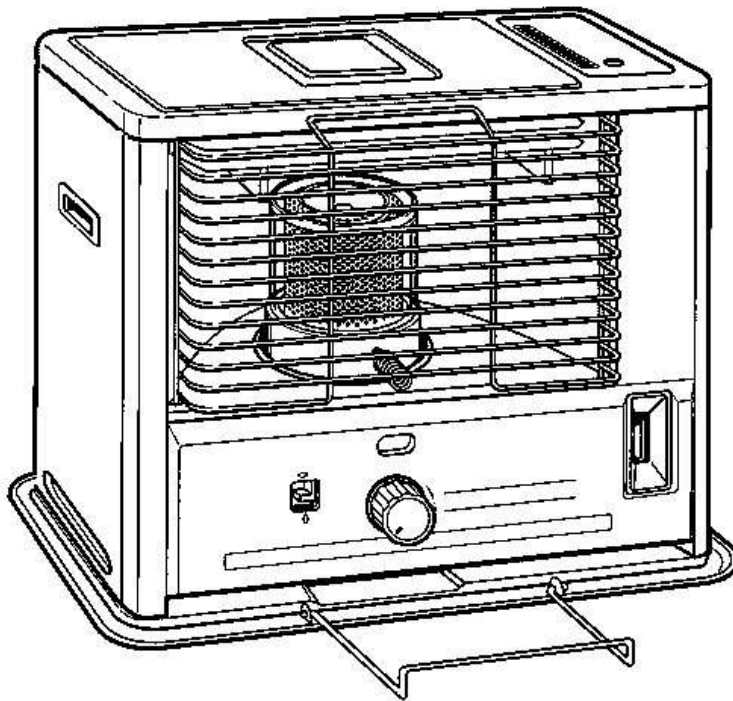

MODEL HMHR-1101



SENGOKU L.A., LTD.

TORRANCE, CA90503

877-GET-HEAT

877-438-4328

TABLE OF CONTENTS

	Page		Page
● CAUTIONS	1	● STORAGE OF KEROSENE	
● FEATURES	2	HEATER	12
● SPECIFICATIONS	2	● WICK-RAISING MECHANISM	
● PRECAUTIONS	3	RADIANT TYPE	13
● USAGE	5	● EXPLODED PARTS	
● DAILY CHECKS AND		DRAWING	14
MAINTENANCE	9	● QUICK CURES FOR	
● REPLACEMENT OF PARTS	11	COMMON TROUBLES	15

Please read this Instruction Manual carefully. It will show you how to assemble, maintain, and operate the heater safely and efficiently to obtain full benefit from its many built-in features.

FEATURES

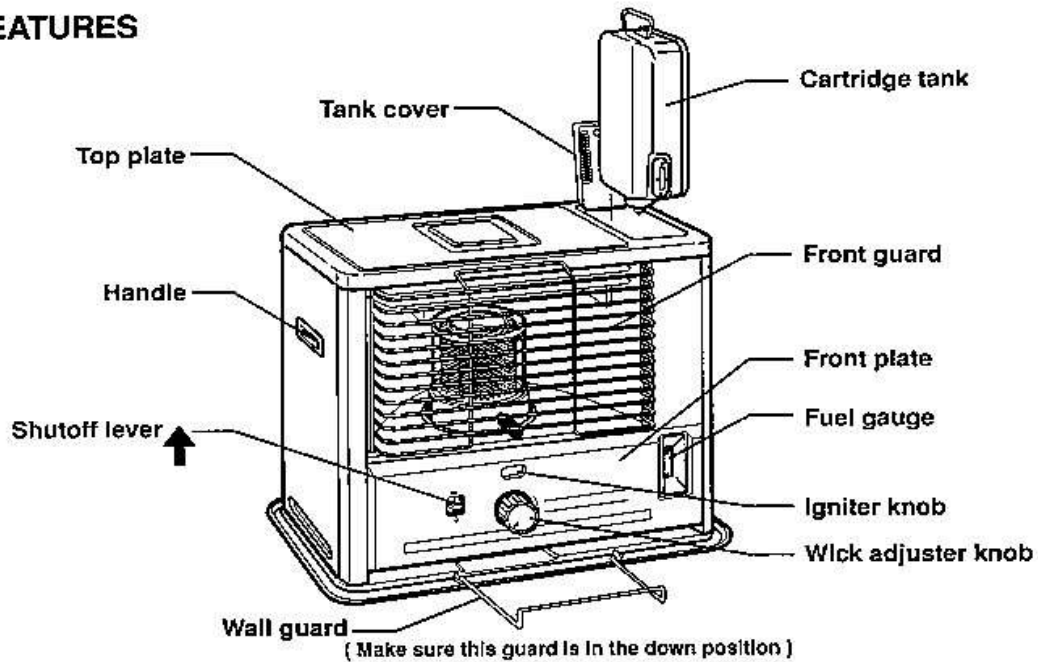

SPECIFICATIONS

Model No.	HMHR-1101		
Type of Heater	Radiant Reflection	Weight (empty)	25 lbs.
Heat Output	Max. 10,600 BTU/hr.	Dimensions	Height
Fuel Tank	Cartridge		Width
Tank Capacity	1.0 U.S. Gallon		Depth
Continuous Combustion Time	12-16 hr.	Max. Wick Height	5/16 IN. (8 mm)
Max. Fuel Consumption	0.07 U.S. gallon/hr.	Wick No.	OS-0011
Ignition Method	Battery - D Cell x 2	U.L. Listed	Yes

PRECAUTIONS

1 FUEL

This kerosene heater was designed to operate with No. 1-K kerosene ONLY. The use of any other kerosene, liquids that are flammable or non-flammable are dangerous. They will contaminate the unit and render it useless or may cause bodily injury, explosion and fire.

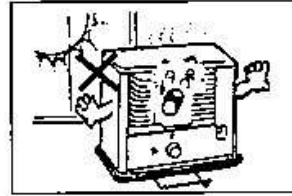
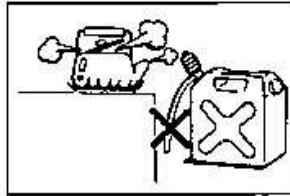
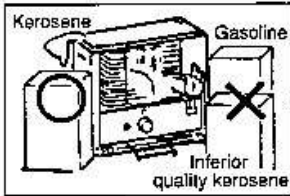

2 PLACE FOR USE

Use a kerosene heater in a level position only.

- Do not use it in a moving vehicle, a vibrating place, near a window curtain or near flammable objects.
- Do not use it under mantelpiece or any high raised area.
- Do not use it in a passage place such as entrance, exit or windy place.
- Do not use it in a room where the temperature is more than 30°C (86°F)

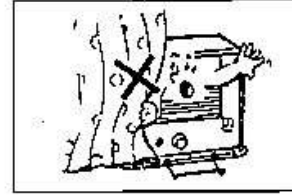
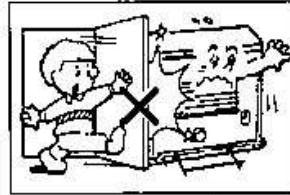
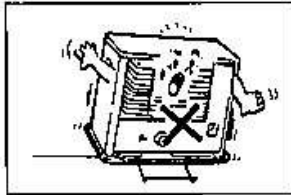

3 REFUELING

- Refuel after the kerosene heater is extinguished and cool to touch.
- It is dangerous to refuel while the heater is in operation or still hot.
- In case of spillage, wipe up immediately. Be sure to close the tank cap tightly. Ignite the wick about 30 minutes after fueling when using it for the first time. After "Carbon Removal", let wick absorb kerosene for 30 minutes before reigniting.

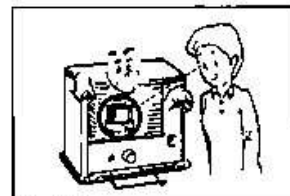
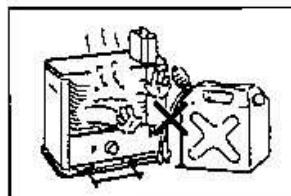

4 USAGE

Wick does not have low or medium flame but burns in one position with blue flame about 1/2 inch high. Refer to Fig. 15, Page 9.

- Ignite the wick in correct order, and confirm the wick is burning normally. Raising the wick too high or lifting the burner causes abnormal burning and can be dangerous. Adjust the flame about 15 minutes after ignition in order to acquire correct combustion.
- Keep the room well ventilated. Do not use the kerosene heater in a place where flammable gases are generated or stored. Shortage of oxygen could cause improper combustion and generate carbon monoxide.
- Do not use the kerosene heater for drying clothes or other flammable objects.
- Do not carry the kerosene heater while the wick is burning or you may cause an accident.

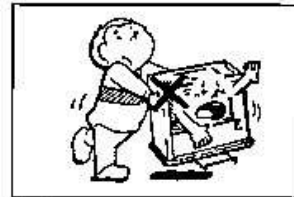
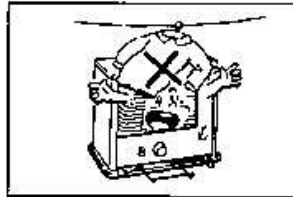
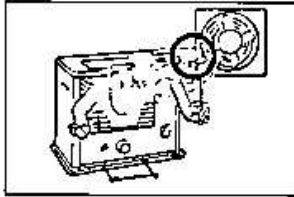

- If the kerosene heater is burning abnormally, push the shutoff lever up. If the flame does not go out, use a fire extinguisher.
- Before you go to bed or leave the room, extinguish the heater, then lift the burner and look at the wick to be sure it is out.
- Do not get excited and turn over the kerosene heater when you extinguish the fire.
- Never touch any portion of top plate during combustion, because it is very hot.
- Never put a pan, a kettle or the like on the heater.
- Never sprinkle the glass cylinder with water.

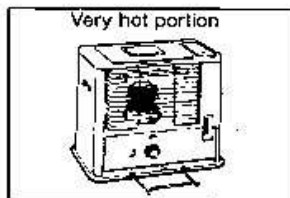
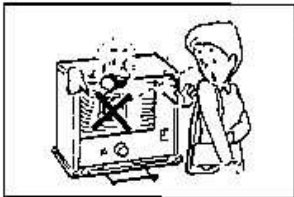

5 DAILY CHECKS AND MAINTENANCE

Perform complete check and maintenance. (Details are described on page 9)
Remedy any problem immediately even if it is a minor one. It is dangerous to operate the kerosene heater when a problem exists.

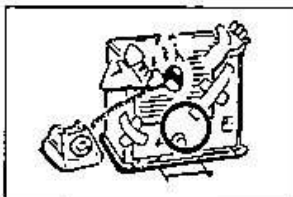

USAGE

1 PREPARATIONS

(A) Unpacking

- Take the heater out of the cardboard box and remove pads. Take batteries out of styrofoam and return styrofoam to carton and save.
- Pull the right-hand side of the front guard to open it. Remove pads protecting the burner and take out the burner.
- Open the tank cover and take out the upper packing protecting the cartridge tank and bottom cardboard. (Fig. 1)
- Keep the cardboard box and all inside packing as a "Storage Box". Also keep the "Owner's Manual".
- Make sure the wall guard is in the down position.

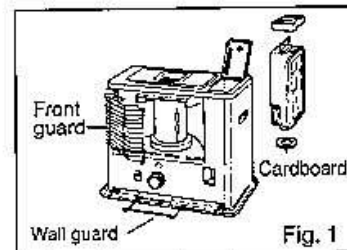

(B) Installing batteries

Install batteries in the battery case at the back of the kerosene heater with correct polarity. (Fig. 2)

CAUTIONS FOR BATTERY USAGE

- Do not use a new battery with a used one.
- Never charge dry batteries.
- Batteries must not be heated, mutilated, shorted or thrown into fire.
- Remove dead batteries at once. Also remove batteries when not in use or when stored for summer.

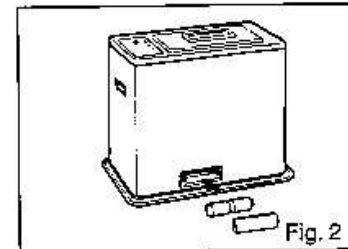

(C) Setting burner

Test the tip-over extinguishing device and observe if the wick is lowered down. To test, turn the wick all the way up and press up the shutoff lever. Wick should snap down to lowest possible level. Place the burner on the wick adjuster. Confirm the burner is set properly by rotating the burner knob left and right two or three times. (Fig. 3)

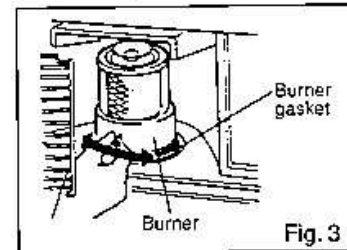

2 REFUELING

(A) Fuel to use

- (1) Use only clear or red colored **No. 1-K kerosene** or **Exxon Clear Lite** for fuel. Do not use **GASOLINE** or **LIGHT OIL** or any other fuel but **No. 1-K kerosene**. Specific gravity of kerosene is about 0.8, and its ignition point is more than 40°C (104°F). To distinguish kerosene from others, take half a teaspoon of fuel and bring it close to a lit match. If the fuel has a low ignition point (such as gasoline or thinner), it will burn, but if it is pure kerosene (No. 1-K kerosene), it will not. (Fig. 4)

Kerosene in the USA is sometimes dyed red due to tax laws and the red dyed kerosene should be translucent (able to be seen through) and not cloudy.

- (2) If improper kerosene or deteriorated or impure kerosene is employed, within 3 to 20 hours the wick will be covered with excessive carbon. The following will take place and impair the kerosene heater.

- The burner will not get completely red, letting off the strong odor of incomplete combustion.
- It will become hard to ignite the wick and, even if it is ignited, the flame will die out soon.
- The upper and lower parts of wick become stiffened so that the flame will not extinguish despite pushing up the shutoff lever.

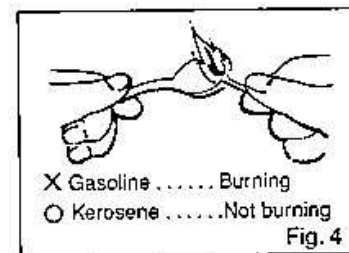

(3) Improper kerosene

a) Deteriorated kerosene may be caused by the following:

- Kerosene kept over from the preceding season.
- Kerosene stored for a long period of time in a sunlit place.
- Kerosene stored for a long period of time in a place of high temperature.
- Kerosene mixed with other fuel oils such as diesel fuel, heating fuel oil or bad kerosene. In any of those cases, kerosene will easily deteriorate.

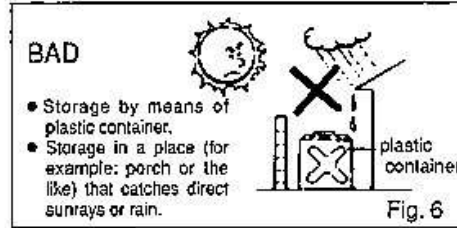
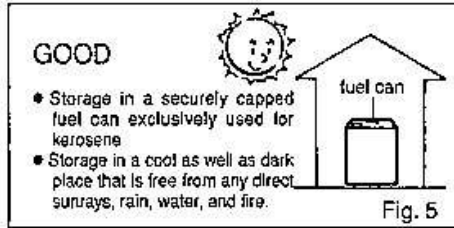

b) Impure kerosene

- Kerosene mixed with other kinds of oil such as cooking oil, machine oil, diesel fuel or other foreign fuels.
 - Kerosene mixed with water or dirt.
 - Kerosene mixed with anything else not recommended by manufacturer. Never use a container that has been used to store gasoline. Make sure inside of can is free of rust.
- (4) It is quite difficult to separate proper kerosene from deteriorated or impure kerosene. Therefore care should be taken to distinguish good quality from the BAD. Kerosene should not be kept over from the preceding season. Avoid using kerosene that is unreasonably low in price.

(B) Procedures and cautions for refueling

- (1) Be sure to extinguish the kerosene heater and let it become cool to the touch before refueling. (Do not remove the cartridge tank while heater is burning or it is still hot.) (Fig. 7)
- (2) Use the enclosed siphon for refueling. Procedures for using the siphon. (Fig. 8)

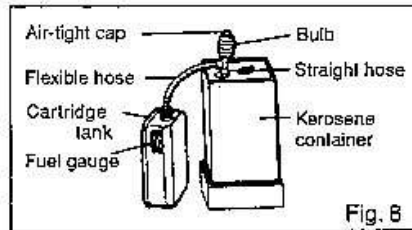
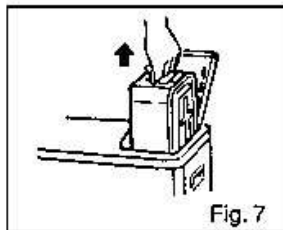

- (a) Tighten the air-tight cap located on the top of siphon.
- (b) Insert the straight hose into the kerosene container.
- (c) Insert the flexible hose through the opening of cartridge tank.
- (d) Squeezing the bulb repeatedly, refuel by watching the fuel gauge.
- (e) When the fuel level rises up to the center of fuel gauge, loosen the air-tight cap. (Fig. 9) Allow siphon to drain before removing from tank and container.
- (3) Fasten the tank cap to the cartridge tank securely.
- (4) Wipe up any spilled kerosene thoroughly.
- (5) Set the tank into the kerosene heater properly. (If the cartridge tank is set improperly, the cover on cartridge tank will not shut.)
- (6) Please check that push pin is seated properly before replacing tank. Do not drop the tank into the heater. When tank is replaced a gurgling sound will be heard signifying that fuel is being released into reservoir.

NOTE

- Extinguish the kerosene heater and refill the tank before the fuel reaches the bottom of the cartridge tank. (Fig. 10)

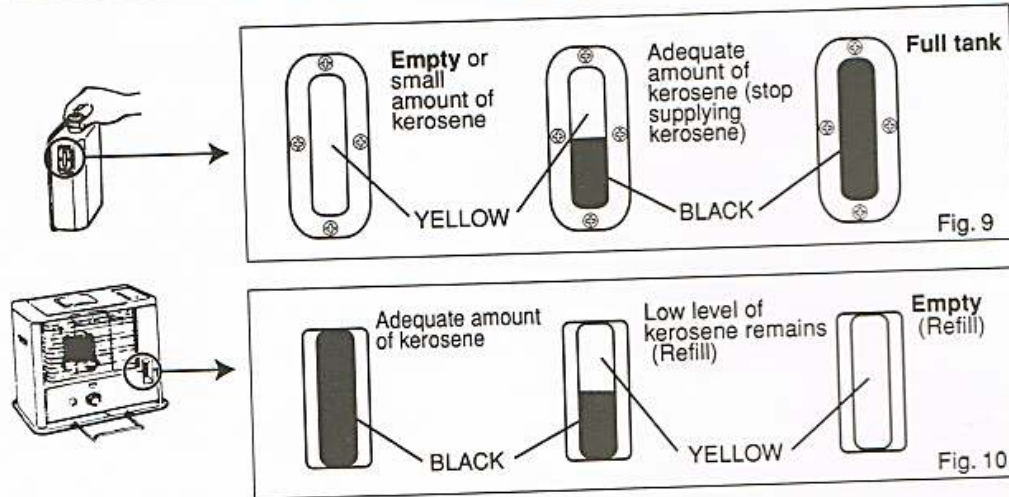

3 PREPARATION PRIOR TO IGNITION

The kerosene heater should be used in a level position or improper combustion may result. When using it on a slanted floor or in an unstable position the tip-over extinguishing device may be actuated automatically.

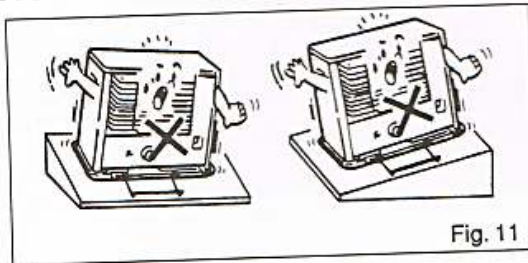

4 IGNITION

Do not carry the heater while wick is burning. Wait for 30 minutes the first time the tank is filled to allow the wick to become saturated with kerosene before igniting the wick. If the wick is used before saturating with kerosene enough, the wick will be permanently damaged.

- Reset the shutoff device by pushing the shutoff lever to left, if heater has been tipped.
- Fully turn the wick adjuster knob clockwise to raise the wick to the maximum height. When the wick is completely up the arrow mark of the control dial will point to the "HIGH POSITION".
- Ignition by igniter**
Push the igniter knob.
The burner tilts for ignition.

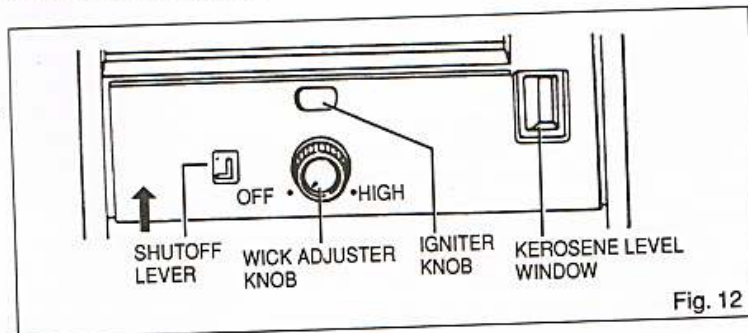

(D) Ignition by a match

- A broken igniter wire or dead batteries should be replaced with new ones. If a match is used, open the guard and light as illustrated. (Fig. 13)
- Never leave a burnt match on the wick adjuster or horizontal reflector. Incomplete burning or fire may occur.

(E) After igniting the wick rotate the burner knob to left and right a few times to ensure that the burner rests properly on the wick adjuster. (Fig. 14)

- Reigniting the wick soon after extinguishing the kerosene heater (the burner is still hot at this time) will cause the burner to generate heavy odor. To avoid it, wait for about 10 minutes before reigniting.

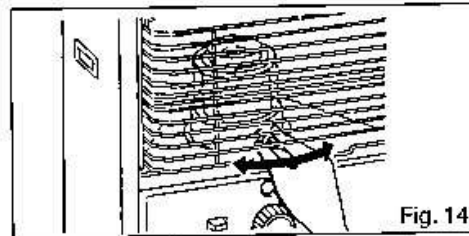
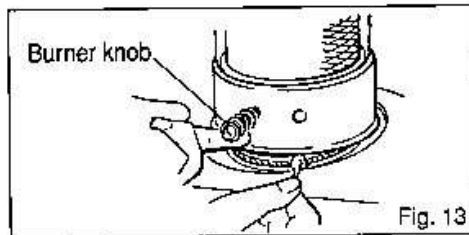

NOTE

- During initial use, a slight odor may be noticed. This is caused by evaporation of anticorrosion oil and therefore not abnormal. This odor disappears after new burner has been used 3 to 4 hours.
- Pushing the ignition knob with excessive force may cause the igniter to be caught by the wick. Ignition may not occur. Release the igniter knob slightly, and ignition becomes easier. Pushing the igniter knob too little will result in failure of ignition because the igniter is too far away from the wick.
- As illustrated, the optimum distance between the wick and igniter is 1/64-1/32 in. (0.5 to 1 mm). If ignition is difficult, correct deformation of filament.
- Reigniting after the operation of tip-over extinguishing device should be made after 10 minutes. Reigniting immediately after extinguishing will cause non-ignition, white smoke or strong odor.

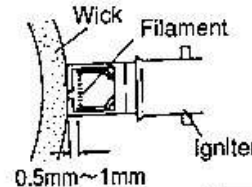

5 FLAME ADJUSTMENT

IF THE FLAME SHOWS YELLOW FLICKERS, TURN THE WICK ADJUSTER KNOB DOWN SLIGHTLY SO ONLY BLUE FLAME APPEARS.

FOR FINE ADJUSTMENT OF THE FLAME, GRASP THE BURNER KNOB AND MOVE IT FROM SIDE TO SIDE AND FRONT TO BACK UNTIL THE BLUE FLAMES ARE AS EVEN AS POSSIBLE. ALWAYS ALLOW A FEW SECONDS REACTION TIME AFTER ADJUSTING TO ALLOW THE FLAME TO STABILIZE.

THE FLAME MAY NEED TO BE ADJUSTED DURING THE BURNING PERIOD, AS THE HEATER BODY WARMS UP CAUSING THE KEROSENE TO VAPORIZE FASTER.

REASON: THE BURNING RATE CHANGES AS UNIT AND ROOM TEMPERATURES CHANGE.

- REGULATING THE WICK ADJUSTER KNOB TOO LOW OR TOO HIGH WILL PRODUCE CARBON ON THE WICK AND WICK ADJUSTER WHICH WILL RESULT IN IMPROPER COMBUSTION OR IN STIFFENING OF THE WICK. THEREFORE YOU MUST MAKE ADJUSTMENT TO OBTAIN NORMAL FLAME. (See Fig. 15)

During normal operation, you will, on occasion, hear the bubbling sound of the fuel from the cartridge tank filling the fuel reservoir area. This sound is a normal characteristic of kerosene heaters that use cartridge tanks.

NOTE

- Do not turn the wick adjuster knob lower than range of the FLAME ADJUSTMENT. If the heater is used at lower than wick stop intentionally, it may cause the generation of odor or CO, flaring up, etc.



<p>BAD</p>  <p>● Flame too low ● Improper combustion results ● Produces odor fumes ● Reduces heat efficiency</p> <p>CURE: Raise the wick as high as it will go until burner metal inside the glass glows red from top to bottom.</p>	<p>GOOD BLUE FLAME</p>  <p>● Normal flame ● Perfect combustion</p> <p>PERFECT COMBUSTION AND MAXIMUM HEAT OUTPUT. Do not try to reduce heat or save kerosene by lowering the wick.</p>	<p>BAD YELLOW FLAME</p>  <p>● Flame too high ● Improper combustion ● Produces odor ● Reduces heat efficiency</p> <p>CURE: Lower the wick slightly until the yellow flicker in the flame disappears and only blue flame remains.</p>
---	---	--

Fig. 15

6 EXTINGUISHING THE HEATER

To extinguish, push up the shutoff lever. If the wick is not lowered by the shutoff lever, keep pressing the shutoff lever up and turn the wick adjuster knob counterclockwise (OFF direction) to the limit. In about 2 to 3 minutes, lift up the burner knob to confirm extinguishment. (Fig. 16)

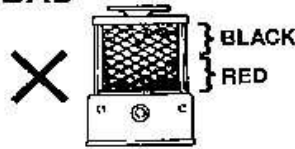
NOTE

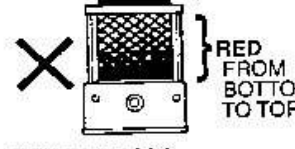
- When a large amount of carbon adheres to the wick, the wick may not lower completely by pushing up the shutoff lever, which could result in the flame not extinguishing. In this case, keep pressing the shutoff lever up and turn the wick adjuster knob counterclockwise (OFF direction) to the limit and carry out the inspection and maintenance described on Page 9.
- The tip-over extinguishing device may function if heater is given a shock by hitting or shaking.
- Never disassemble or adjust the tip-over extinguishing device. Otherwise the tip-over extinguishing device may not operate correctly in case of emergency.

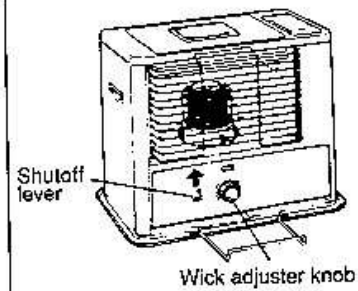

Fig. 16

DAILY CHECKS AND MAINTENANCE

Always keep kerosene heater clean. The reflector should be free of dust, film, grease, oil, etc. Using a dirty kerosene heater is dangerous, and also shortens the life of the kerosene heater.

NEVER TRY TO REPAIR THE FOLLOWING PARTS MENTIONED BELOW AT HOME.

- Fuel gauge Do not unfasten the screws to disassemble the fuel gauge from the tank.
- Tip-over device Do not disassemble the shock sensitive section of the tip-over extinguishing device, and do not allow kerosene to spill on this device.
- **Inspection of cartridge tank**
Is there kerosene in base plate while using the kerosene heater?
Is there rust or foreign matter in the tank?
Are there any dents or cracks in the tank?
If so, replace the tank with a new one.
- **Inspection of wick adjuster and wick guide cylinder**
Inspect as often as possible to see if carbon has accumulated. When the carbon has accumulated, remove it by (-) screw driver after fully lowering the wick.

- **Inspection of Igniter**

If the wick does not ignite or it is hard to ignite with battery ignition, check if the igniter filament is broken. (Fig. 17)

A slight distortion of igniter filament can be corrected with a match-stick; however, when the filament is stretched out or broken, replace it with a new one. Insert the new igniter into the socket carefully so as not to damage igniter filament.

Refer to page 12 (Fig. 27)

NOTE : Remove batteries before replacing Igniter.

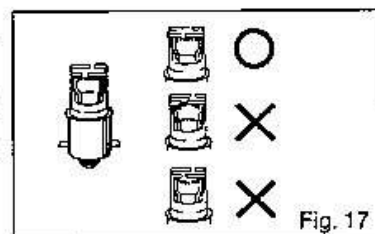

Fig. 17

- **Checking batteries**

In the event of low battery voltage (when the shape of igniter filament is normal), igniter filament will not get hot enough. In this case, replace batteries.

- **Check condition of wick (and how to replace, see Page 11.)**

Check the wick height — 5/16 inch (8mm), see Fig. 25 of "Wick Replacement" — and uniformity of the height.

Also check if carbon accumulates on the wick. If carbon accumulates, perform "Carbon Removal" as mentioned below.

IMPORTANT

- **WICK MAINTENANCE**

The top of a fiberglass wick accumulates carbon in the process of burning kerosene. This must be removed to maintain peak efficiency in burning. It is most important that you feel for carbon hardness after second or third tankful of fuel. A wick in good condition will feel soft while one that is carbonized will feel like a bristle brush or, in late stages, top could be coated with hard black carbon. Check for resistance when turning the wick adjuster knob; check if burner is fully red; check if it is difficult to ignite by the igniter. Any of these troubles result from carbon on the upper part of the wick. To get rid of carbon, perform the "Carbon Removal" in the following procedure.

- **CARBON REMOVAL**

Carry out the "Carbon Removal" out of doors if windless, on a porch or the like or in a room with its window(s) open because a strong odor is produced.

(a) With the cartridge tank having only a small amount of kerosene, keep the wick burning without refilling with kerosene even when the tank becomes empty. When flame starts to burn out, raise wick fully and leave it there till it burns out. Wait approximately 30 minutes then relight wick with match if necessary, and allow it to burn out again. When it cools, remove any remaining ash with an old toothbrush.

(b) The upper part of the wick will be rid of carbon with this operation and be softened. However if any parts are still left stiff, pinch them by means of small pliers to fracture carbon into pieces, supply a small amount of kerosene to tank and once more perform the "Carbon Removal". After carbon has been removed, refill tank and wait 30 minutes before igniting wick.

(c) In addition, carry out the "Carbon Removal" within 5 to 7 days after the first use of the kerosene heater, and carbon accumulation to the wick can be reduced. Thereafter perform the "Carbon Removal" every 5 or 6 tank fulls of kerosene.

If any water gets into the cartridge tank or when the season for kerosene heaters comes to an end, completely remove all kerosene from the cartridge tank and sump tank. **VERY IMPORTANT!**

NOTE

"CARBON REMOVAL" SHOULD BE DONE WEEKLY DURING THE HEATING SEASON UNLESS NEEDED MORE FREQUENTLY. CHECK TO BE SURE.

REPLACEMENT OF PARTS

1 WICK REPLACEMENT

Wick replacement should be performed on a completely cool heater after the cartridge tank has been removed and the remainder of the kerosene in the heater has been burned off.

- (1) Open the tank cover and remove the cartridge tank. Remove the batteries from the heater. Open the front grille and remove the chimney. Remove the wick adjusting knob by pulling straight out.
- (2) Unscrew 3 screws from the back and each side of the cabinet and carefully lift off the cabinet.
- (3) Unscrew the screw which holds the wind cover and take off the wind cover.

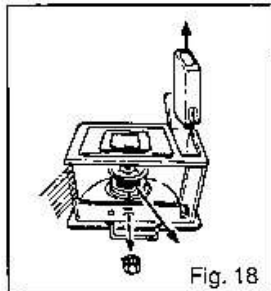

Fig. 18

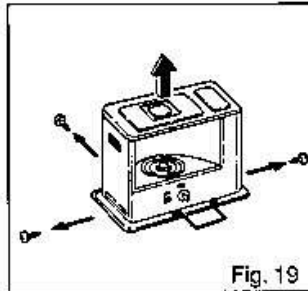

Fig. 19

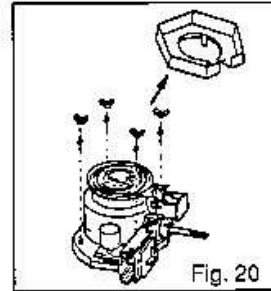

Fig. 20

- (4) Remove the automatic ignition assembly by unscrewing 2 screws.
- (5) Unscrew 4 wing nuts and lift off the wick adjuster assembly.
- (6) Remove the wick from the holder by folding it inward. Loosen it from the sharp metal teeth on the inner surface of the holder, then slide it out. **Caution: the teeth are very sharp.**

- (7) Replacement wick has black line. Fold the new wick and slide it into the holder up to the line. The black line on the outside of the wick should match the top edge of the holder. Then carefully press the wick against the teeth inside the holder to obtain a firm grip.

- (8) Slide the wick and holder back on the draft tube. Rotate them 90 degrees left and right and up and down until the wick slides freely. Check to see that the gasket is still in place on the burner tank.

- (9) Replace the wick adjusting knob on its shaft.
- (10) Check to see that the spring of the wick adjuster assembly is free of torque (has no tension).

- (11) Slide the manual shut off lever to left so that its latch may engage with the ratchet.
- (12) Use the knob to rotate the wick control shaft clockwise by 3/4 turn. This rotates the ratchet clockwise by 3/4 turn. Hold the latch to prevent the safety shut off device from being activated.
- (13) Insert the pinion on the inside of the wick control shaft into top portion of the rack of the wick holder. This step should be done easily if the wick holder is raised near the top of the draft tube.
- (14) Slide the wick adjuster assembly down the draft tube. Position the adjuster shaft to the front of the heater. Make sure 3/4 turn tension on the spring is kept. Turn the knob clockwise and counter-clockwise a few times to make sure the wick travels up and down smoothly.
- (15) Snug but do not tighten 4 wing nuts on the mounting studs, then raise the wick to the full "up" position, and evenly tighten wing nuts in several steps.
- (16) Check height of wick (8 ± 1 mm). Check for correct clearance between wick holder and draft tube (all around). This can be done easily using a 5/32 or 3/16 dia. drill bit.

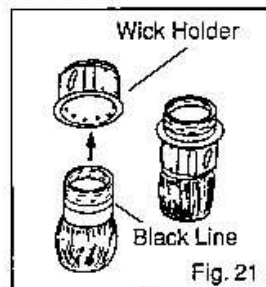

Fig. 21

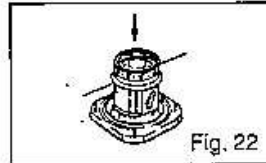
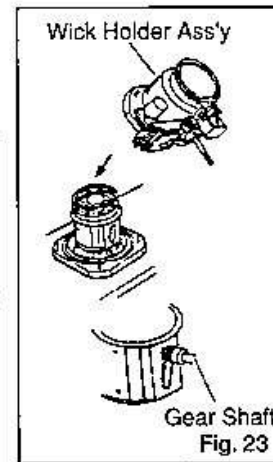

Fig. 22



Gear Shaft
Fig. 23

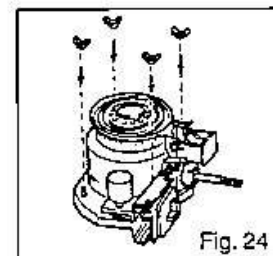

Fig. 24

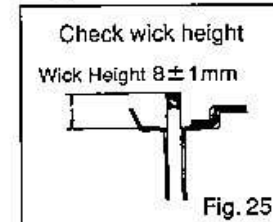
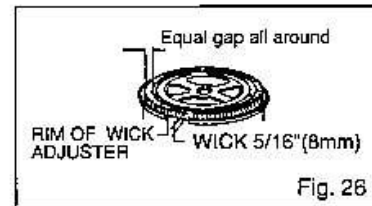

Fig. 25

- (17) Check the function of safety shut off mechanism by lifting the manual shut off lever or upsetting the pendulum.
- (18) Reinstall the automatic ignition assembly and replace the wind cover.
- (19) Remove the wick adjusting knob once again, if it was reinstalled at step (9), then replace the cabinet and tighten 3 screws on the cabinet.
- (20) Reinstall the chimney and the cartridge tank. Close the front grille and replace the wick adjusting knob.



Install the batteries in the battery case. Fill the cartridge tank with clean, pure 1-K kerosene. Replace the tank in the heater and wait at least 30 minutes for kerosene to fully saturate the new wick.

IMPORTANT! If this is not done air bubbles may form in the wick reducing its ability to draw up kerosene. Remember to "dry burn" the new wick after each 5 or 6 tankfuls of kerosene are consumed.

2 IGNITER REPLACEMENT

Be sure igniter is 2.5V DC, 1A only.

- (1) Remove batteries from case.
- (2) Open the guard and remove the burner.
- (3) Push the igniter knob. To remove the igniter push in and turn counterclockwise. Install new igniter and reassemble burner, and close the guard. Then install batteries.

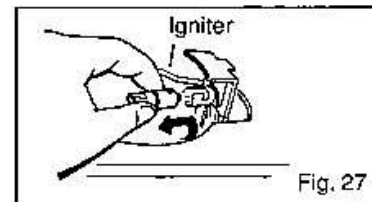

3 GLASS CYLINDER REPLACEMENT

Remove speed nuts holding cross pins. Then pull out cross pins. Replace glass cylinder.

In reassembling, make sure that inner and outer cylinders are set in their proper places.

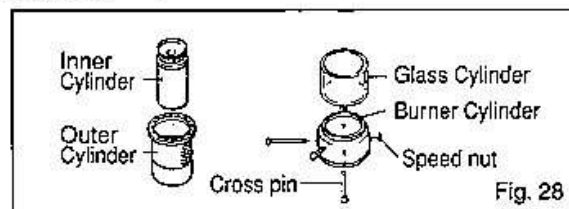

STORAGE OF KEROSENE HEATER

Store the kerosene heater carefully using the following procedure so it will operate safely next season.

- (1) Agitate and rinse inner part of the tank with a little of remaining kerosene, then pour out entirely. Water rarely mixes with kerosene, and it would cause rust inside the tank. Remove kerosene and dry the inside of tank well.
- (2) With no kerosene left in the kerosene heater, ignite and keep the wick burning. When the red heat of the outer cylinder becomes faint, keep the wick fully turned up until it burns out (about an hour).
- (3) After removing the burner and batteries, remove the wick adjuster from the fuel reservoir, dry the inside of the fuel reservoir thoroughly. Remove the carbon accumulated on the wick adjuster and/or the soot adhering to the burner with a brush or screw driver.
- (4) After cleaning, reassemble the heater. Remember to reassemble the wick adjuster so as to keep the gap between the wick adjuster and wick guide cylinder equal all the way around. (Refer to page 11 "Wick Replacement" and Fig. 26)
- (5) The batteries should be taken out from the battery case because they may leak and corrode the kerosene heater. (Fig. 29)
- (6) Store the kerosene heater with the tip-over extinguishing device deactivated and the wick lowered down.
- (7) Put the kerosene heater in the original box with original packing and keep it in a well-ventilated place. Also keep the "Owner's Manual" with heater. (Fig. 30)

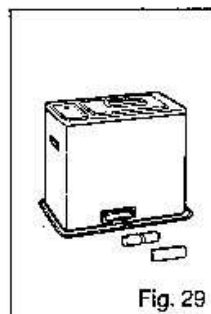

Fig. 29

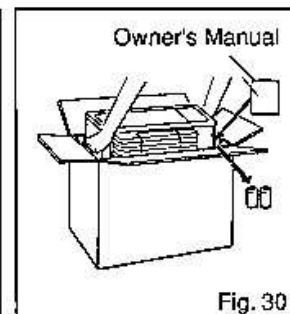
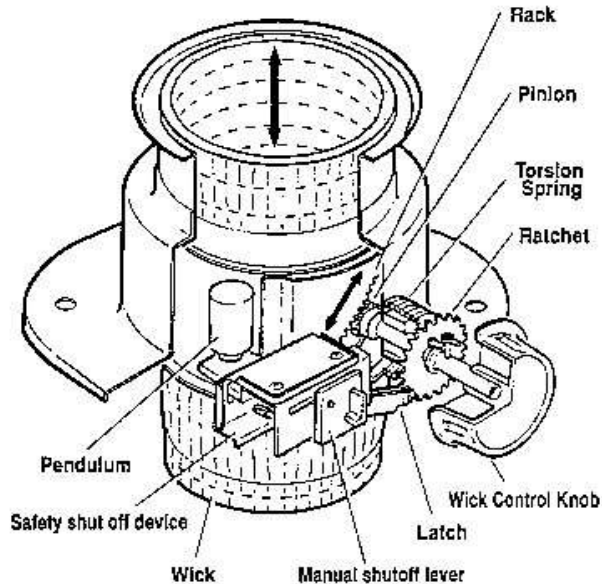

Fig. 30

WICK-RAISING MECHANISM— RADIANT TYPE

Rotating the wick control knob clockwise turns the pinion at the other end of the wick control shaft and causes the rack mounted along the outer circumference of the wick frame to turn. This results in the wick being lifted to the top of the wick holder assembly. As the wick rises, the torsion spring mounted on the wick control shaft is put under tension and compressed. The wick can be contacted by the igniter when in the full "up" position. It is held there against the tension of the torsion spring by the latch that engages the ratchet mounted on the wick control shaft. Pressing the manual shutoff lever up releases the latch, allowing the torsion spring to rapidly lower the wick. The descent of the wick can be slowed by lightly grasping the wick control knob. Lowering the wick slowly in this manner reduces the likelihood of a kerosene odor.



FUNCTION OF THE AUTOMATIC SAFETY SHUTOFF DEVICE

The safety shutoff device is built into the wick raising and lowering mechanism. It is a primary safety system in a kerosene heater. Its purpose is to prevent the spread of flame should a heater be accidentally tipped over while in use.

It functions in the following manner. When the pendulum starts to swing because of a shock, it causes the latch to be retracted from the wick control shaft ratchet. This permits the torsion spring to quickly retract the wick to the fully lowered position. The resulting quick drop puts out the flame.

IMPORTANT: For the automatic safety shutoff mechanism to function as intended, the wick must be free of gummy tar deposits. This can be accomplished by regularly "dry burning" the wick as described on page 10 under "Wick Maintenance" and "Carbon Removal/ Dry Burning."

CAUTION

The operation of the automatic safety shutoff mechanism should be checked periodically, i.e., once a week during the heating season. This can be done by using the wick control knob to raise the wick to the fully upright position. **DO NOT LIGHT THE WICK FOR THIS TEST.** Grasp the upper corners of the protective grille and give the heater a firm shake. If the safety shutoff is working correctly, you will hear a loud snap as the latch disengages from the ratchet and the torsion spring quickly drops the wick. Now attempt to rotate the wick control knob counterclockwise. A correctly functioning automatic tipover device will lower the wick completely. If you are able to lower the wick further, this indicates it is time to "dry burn" for carbon and tar removal again.

NOTE: Every time the wick is removed and replaced, the safety shutoff must be tested to insure it is operating properly.