

**Stay Warm With Someone You Know**

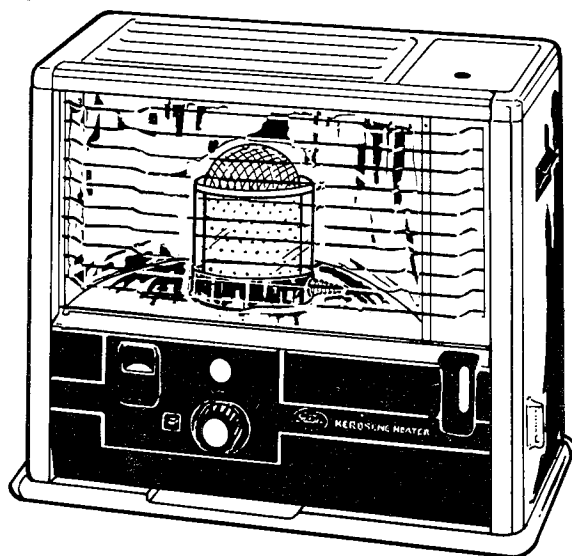

Miles Stair's  
**Wick Shop**  
Quality Kerosene Items since 1999

# KEROSENE HEATERS OPERATING AND MAINTENANCE INSTRUCTIONS FOR MODEL 3602



**It's Important to Use Only Water-Clear  
ASTM D-3699-78 No. 1K Kerosene**

**NEVER USE**

Fuel Oil  
or  
White Gas

Gasoline or  
Diesel Fuel

Naphtha  
or  
Benzol

**USE ONLY**

Water Clear  
ASTM D-3699-78  
No. 1K Kerosene

Versión española disponible: Escriba Vd. a Northern Electric Company, 5224 N. Kedzie Ave., Chicago, IL 60625  
Atención: Departamento de calentadores de querosén, Modelo 3602

You have just purchased one of the finest Portable Kerosene Heaters sold --- A Sunbeam Kerosene Heater. You will be pleased with the service of your new Sunbeam heater if you follow and adhere to these instructions and most importantly --- **ALWAYS USE THE PROPER GRADE OF KEROSENE.**



## YOUR KEROSENE HEATER SPECIFICATIONS:

Model Number:	3602
Heating Capacity:	11,000 BTU/hour
Fuel Type:	Water-Clear ASTM D 3699-78 No. 1K Kerosene
Fuel Tank Capacity:	.98 Gallons
Burning Time:	18 Hours
Typical Room Size:	Approximately 325 sq.ft.

<b>INDEX</b>	<b>PAGE</b>
Introduction .....	2
Specifications .....	2
Fuel Guide .....	3
Important Safety Rules .....	4,5
How to Unpack your Heater .....	6
Assembly .....	6
Filling Your Heater with Fuel .....	7
Lighting Your Heater .....	7
Flame Adjustment .....	8
Turning Off .....	8
Wick Maintenance .....	9
Trouble Shooting Guide .....	10
Wick Replacement .....	11,12
Ignition Heater Replacement .....	12
In Case of Accident .....	13
Storing the Heater .....	13
Warranty .....	13
Service Stations .....	14,15

# IMPORTANT RULES FOR THE SAFE OPERATION OF YOUR KEROSENE HEATER

**READ these Safety Rules and UNDERSTAND the Operating Instructions Before Starting or Servicing your Kerosene Heater.**

1. Improper use of the heater can result in serious bodily injury due to hazards of fire, carbon monoxide poisoning, and burns.
2. **EXPLOSION RISK**
  - A. Use Water-Clear ASTM D 3699-78 No. 1K Kerosene Only.
  - B. Uncontrolled Fire, Explosion or Asphyxiation can result when you use Gasoline, White Gas, Coleman Fuel, Diesel Fuel, Fuel Oil, Naphtha, or solvents such as Alcohol, Acetone, Petroleum, Distillates or any substitute.
  - C. Always fill fuel tank outdoors. Do Not pour kerosene into the tank while unit is hot or still burning. Take precautions to prevent spilling. Always wipe off tank after refueling. Close the filler cap tightly to prevent leaking of fumes which can cause an unpleasant odor and fire hazard.
  - D. Use this heater only in areas free of flammable vapors or high dust content.
  - E. Always keep kerosene container closed. Store kerosene in an approved safety container away from heat sources and open flames.
3. **ASPHYXIATION RISK**
  - A. Ventilation — Always provide a source of fresh air. Either a two-inch door opening to an adjoining room, or a window opened an inch. Kerosene heaters use oxygen and therefore may cause asphyxiation if used in a small room or closed areas such as a bathroom.
  - B. This heater **SHOULD NOT** be used in Campers, Trailers, or the like, at any time!
4. **FIRE RISK**
  - A. The glass chimney must be seated properly. Carefully read the directions under "Lighting Your Kerosene Heater" and follow the Fire Risk instructions to assure proper seating of the glass chimney.
5. Do not use kerosene heater until base tray has been installed.
6. When turning off your kerosene heater, make certain the flame is completely extinguished, using the wick adjustment knob.
7. Always locate the heater at least 4 feet from furniture, walls and other combustible materials. Keep draperies and clothing away from the top and sides of the heater.
8. After the heater is lit, **Do not** attempt to re-ignite the wick. This will damage the heater.

9. Always operate the heater on a level surface away from wind and drafts. See illustrated picture.

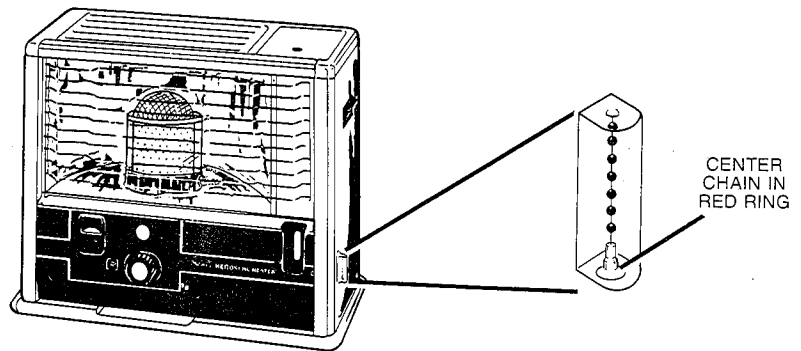

10. Keep Children and Pets away from heater.
11. Never leave heater unattended. Turn off heater when leaving room or while napping or sleeping.
12. Check the heater frequently to be sure it is burning properly, see diagram on page 8.
13. Do not move, handle, service or refuel heater while burning or hot.
14. The heater should not be used in hallways, entranceways or other congested areas where people may gather.
15. Do not use the heater for drying clothes or other articles.

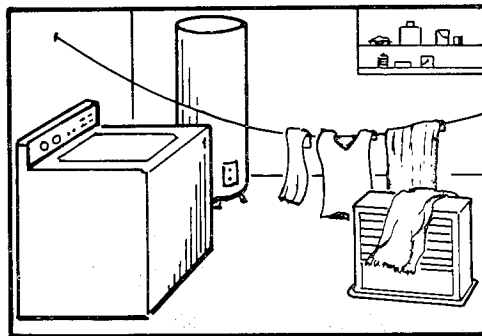

16. Do not place heater in direct sunlight or areas with temperatures above 85°F (30°C).
17. Do Not clean the wick with sharp implements such as knives or scissors while heater is hot. See Wick Maintenance, page 9.
18. Do Not alter or modify the heater in any way!
19. A fire extinguisher must be in close proximity to the heater.
20. A smoke detector must be in the area.
21. Certain states and municipalities may have statutes, codes and laws which may prohibit the use of this device at certain locations. Consult your local building department or other recognized authority to determine if your intended use is permitted.



Miles Stair's  
**Wick Shop**  
www.MilesStair.com  
Quality Kerosene Items since 1999

# FILLING YOUR KEROSENE HEATER WITH FUEL

**WARNING: Carefully read through the Fuel Guide, Page 3, before filling fuel tank with kerosene.**

## HOW TO FILL THE SELF-CONTAINED FUEL TANK

1. Your heater should be cold and shut off.
2. Open the tank cover and lift out the cartridge fuel tank. The cartridge fuel tank should always be filled outdoors.
3. Unscrew the fuel tank cap counterclockwise to remove.
4. Fill the cartridge fuel tank using the syphon pump supplied with your heater.
  - A. The syphon pump is easy to use when you follow these directions. Insert the straight tube of the syphon into the kerosene container. Insert the syphon's flexible hose into the cartridge fuel tank and push it to the bottom of the fuel tank to reduce the possibility of fuel spillage.

**For easier filling, raise the kerosene container so that it is higher than the cartridge fuel tank.**

**CLOSE** the air vent in the syphon pump, located in the top, by turning the knob clockwise. Now, squeeze the bulb vigorously six or seven times, be certain to pause to allow the bulb to expand after each squeeze.

**When the kerosene begins to flow, it is no longer necessary to squeeze the bulb.**

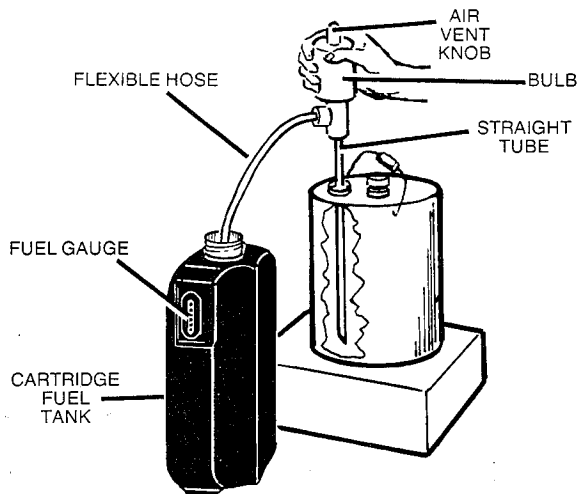

Avoid overfilling the cartridge fuel tank. **WATCH THE FUEL GAUGE. WHEN THE YELLOW VIEWER STARTS TURNING DARK, STOP THE FLOW OF KEROSENE BY OPENING THE AIR VENT. TURN KNOB COUNTERCLOCKWISE. NEVER OVERFILL THE CARTRIDGE FUEL TANK.** Slowly remove the flexible hose from the cartridge fuel tank and allow the excess kerosene to drain back into the kerosene container.

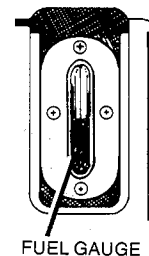

4. Wipe off any spilled kerosene on the heater.
5. Replace and tightly screw fuel tank cap onto cartridge tank.

# LIGHTING YOUR NEW KEROSENE HEATER

**Before lighting your new Sunbeam Kerosene Heater, carefully read the Important Safety Rules on Page 4.**

1. If the cartridge fuel tank is new or has been empty for some time, or if the wick is new, wait 20 minutes after fuel filling for the wick to absorb sufficient kerosene to permit proper operation of your heater.
2. Place kerosene heater at least four feet away from walls, furniture, curtains and other flammable materials.
3. It is important that your heater is always placed on a level surface. Check the built-in leveler guide to see if the heater is straight and level. When the heater is level, the chain will hang straight and be in the center of the red circle.
4. Turn the wick adjustment clockwise until it stops. The wick should be raised to its highest position. Never use force while turning the wick adjustment knob.
5. The wire handle located at the base of the glass chimney **MUST** be centered in front of the heater.

## FIRE RISK

**IMPORTANT - THE GLASS CHIMNEY MUST BE SEATED PROPERLY. USING THE WIRE HANDLE, MAKE CERTAIN THE GLASS CHIMNEY ROTATES BACK AND FORTH EASILY AND SMOOTHLY AND SITS LEVEL OVER THE WICK AREA.** The glass chimney should be straight, not tilted in any direction over the wick. If the glass chimney is not seated properly, your kerosene heater will smoke, or may **flare fire violently**. This may also **cause asphyxiation** due to excess carbon monoxide. The flame in the wick should be carefully observed for at least 15-25 minutes and should burn as shown in picture "C" in the Flame Adjustment section.

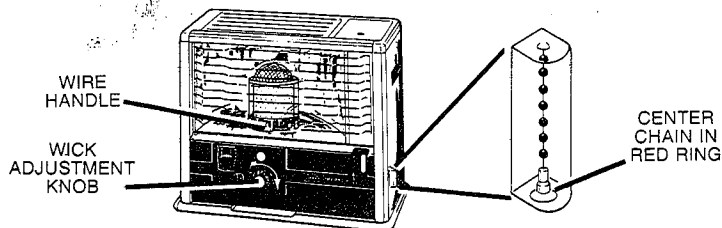
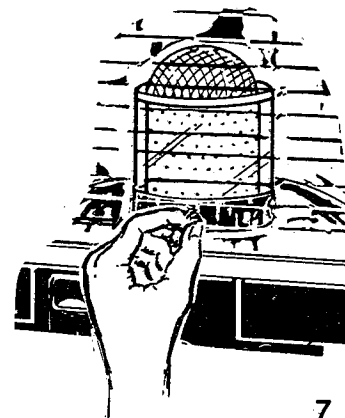

6. **Battery Ignition** - Push the START Ignition Button. The ignition heater should lightly touch the top of the wick. If the ignition heater touches the side of the wick, the wick is too high. Lower the wick by turning the wick adjustment knob counterclockwise. Release the Ignition Button after 3 to 5 seconds. The wick should light automatically. Within 40 to 50 seconds, the flame should spread completely around the wick. (If the flame does not spread around the wick, see Trouble Shooting Guide, Page 10). Before leaving the heater, check to see if the glass chimney is properly seated.

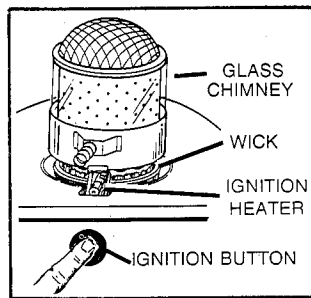

7. **Match Ignition** - If you replace worn out batteries, it should not become necessary to light your heater with a match. Use matches only in an emergency if batteries are not available. Raise wick to its highest level. Push the START Ignition Button to expose the wick. Touch a lighted match to the top of the wick. After lighting wick, do not allow burned match parts to fall on the wick.

A slight odor or smoke is normal after lighting a new heater. Generally these conditions are caused from the preservative oil and paint used on the metal parts. The odor and smoke should disappear after the first tankful of kerosene is used up.

## FLAME ADJUSTMENT

1. Wait 15 to 25 minutes for the burner to reach optimum operating temperature. Then check the wick for proper operation.

Check the mesh guard located at the top of the glass chimney for proper wick burn.

- If the flame is sporadic, jog the glass chimney 2 or 3 times using the wire handle.
- If mesh guard is dark in the upper portion, the wick is too low.
- If the flame is over the top of the mesh guard as illustrated in the last picture, the wick is too high.

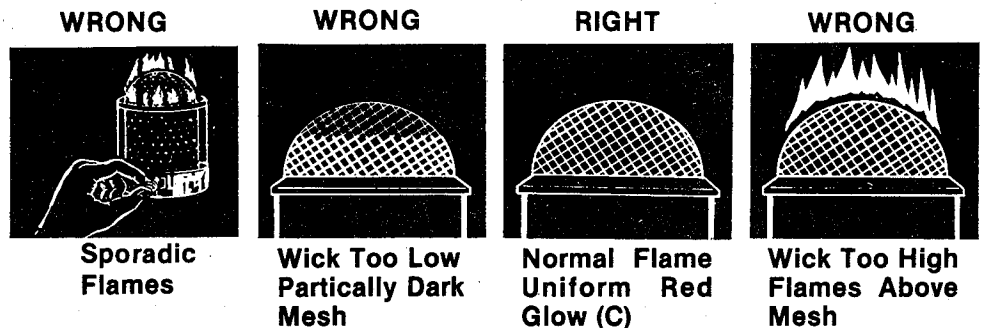

Turn the wick adjustment knob slowly counterclockwise to lower the wick and slowly clockwise to raise the wick.

Be certain to adjust the flame as illustrated in picture (C). The entire mesh should glow evenly. The flame should never be over the mesh guard or be set too low to allow the mesh to become dark at the top.

**OPERATE ONLY AT WICK SETTINGS THAT PRODUCE A FULL RING OF FLAME AROUND THE BURNER. (PICTURE C)**

**NEVER OPERATE THIS HEATER WITHOUT THE GLASS CHIMNEY IN PLACE.**

**NOTE:** Tar will deposit on the top of the wick if the heater is allowed to burn when the wick is set too low. The wick adjustment knob becomes hard to turn when tar deposits accumulate on the top of the wick. The flame should be burning normal (picture C) at all times.

**IMPORTANT:** When the wick burns at the "too low" level, improper combustion can result in excessive CARBON MONOXIDE and RISK OF ASPHYXIATION is possible.

## TURNING OFF AND EXTINGUISHING THE FLAME

1. Turn the wick adjustment knob counterclockwise until it stops. The flame will go out after a few seconds.
  2. Before leaving the heater, check the glass chimney to make certain the flame is out.
2. You will encounter the following conditions when turning off the heater using the manual shut-off switch.
    - A. Smoke and odor will be emitted from the heater.
    - B. A flare-up of flame. This is a normal occurrence when a snap action shut-off is triggered.

### MANUAL SHUT-OFF SWITCH

1. The Manual Shut-Off Switch should ONLY be used if an emergency exists.

These are not unsafe conditions, but may likely be irritating and alarming.

# WICK MAINTENANCE

The wick should last at least one heating season when you clean it properly and use Water-Clear ASTM D 3699-78 No. 1K Kerosene.

**ALWAYS "BURN DRY" YOUR SUNBEAM, MODEL 3602 KEROSENE HEATER AFTER EVERY THREE TANK FILLINGS.**

**"BURN DRY"** When the fuel gauge shows empty, the yellow viewer appears on the fuel gauge, take the heater outdoors or place in a well-ventilated area. Turn the wick adjustment knob clockwise until it stops; the wick is at its highest level. Ignite the heater and let it burn until the flame goes out by itself. The "Burn Dry" method burns off the tar that has accumulated on the wick and restores it to an acceptable operating condition. "Burn Dry" does not harm the Model 3602 wick. During this procedure, an odor and possibly smoke will be emitted from the unit.

## CLEANING THE WICK

1. Before cleaning the wick, be certain your heater is completely cool to the fingers' touch.

2. Open the safety grill by gently pulling the right top end toward you, then up. This easily disengages the vertical grill rail from the bottom retaining hole.

SAFETY GRILL

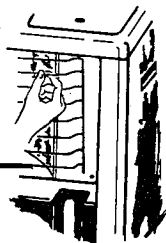

3. Carefully lift out the glass chimney and place on newspaper.

GLASS CHIMNEY

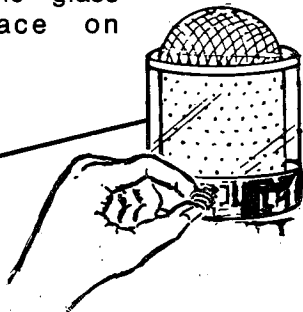

4. Turn wick adjustment knob clockwise until it stops; the wick is raised to the highest level.
5. Gently brush the wick with a used toothbrush to remove the carbon build-up.
6. Vacuum all the carbon build-up, soot, ashes and debris that may be in the burner area.
7. Turn the wick adjustment knob counterclockwise until it stops so that the wick is at its lowest position.
8. Wipe off all carbon, soot, ash or debris from the inside of the glass chimney.
9. Carefully lower the glass chimney onto the heater.
10. **IMPORTANT - THE GLASS CHIMNEY MUST BE SEATED PROPERLY. USING THE WIRE HANDLE, MAKE CERTAIN THE GLASS CHIMNEY ROTATES BACK AND FORTH EASILY AND SMOOTHLY AND SITS LEVEL OVER THE WICK AREA.** The glass chimney should be straight, not tilted in any direction over the wick. If the glass chimney is not seated properly, your kerosene heater will smoke, or may flare fire violently. This may also cause asphyxiation due to excess carbon monoxide. The flame in the wick should be carefully observed for at least 15-25 minutes and should burn as shown in picture "C" in the Flame Adjustment section.
11. Close Safety Grill.

## LOOK FOR THESE SIGNS OF A CONTAMINATED WICK:

- Carbon and tar along the top edge of the wick generally caused by a poor quality of kerosene.
- The size of the flame diminishes or goes out.
- An uneven flame.
- Heater doesn't light easily.
- There is a strong odor; the fumes irritate the eyes.
- It is difficult to ignite the wick, or it is difficult to raise or lower the wick.
- The use of fuel OTHER than Water-Clear ASTM D 3699-78 No. 1K Kerosene will damage the wick.

Clean or replace the wick if any of these problems occur.

# TROUBLE SHOOTING GUIDE

Trouble										
Possible Problem	Soot	Wick hard to light or does not ignite	Flame does not go out	Odor	Flame uneven	Wick adjustment knob hard to turn	Flame extends to high over burner	Flame does not move quickly around wick	REMEDY	Page
Wick too high	○		○	○			○		Lower wick.	8
Wick too low		○		○				○	Raise wick.	8
Wick uneven	○	○	○	○	○	○	○		Adjust or replace wick.	11,12
No fuel		○		○				○	Add fuel.	7
Bad fuel	○	○	○	○		○	○	○	Buy only Water-Clear ASTM D 3699-78 No. 1K Kerosene	3
Water in fuel		○		○		○		○	Drain fuel, replace wick.	11,12
Wick incorrectly attached			○		○	○			Disassemble, attach wick correctly.	11,12
Carbon deposits etc. on wick	○	○	○	○	○	○		○	Clean wick.	9
Batteries dead or not installed properly		○							Replace batteries. Install properly.	6
Ignitor is burned out		○							Replace Ignitor	13
Ignition Circuit defective		○							Take to Service Center	14,15
Reservoir contains deteriorated or impure Kerosene	○	○	○	○	○	○	○	○	Refer to Select & Store Kerosene	3
Gasoline or Thinner mixed in Kerosene	○	○	○	○	○	○	○	○	Refer to Select & Store Kerosene	3
Wick has not absorbed enough Kerosene	○	○		○	○				Lower wick. Leave it set for 60 minutes. Not burning	8



# WICK REPLACEMENT

**NEVER** disassemble your heater while burning or before heater is completely cool.

1. To disassemble your heater, repeat Steps 1, 2 and 3 of Wick Maintenance, Page 9.
2. Open the fuel tank cover and lift out the cartridge fuel tank.

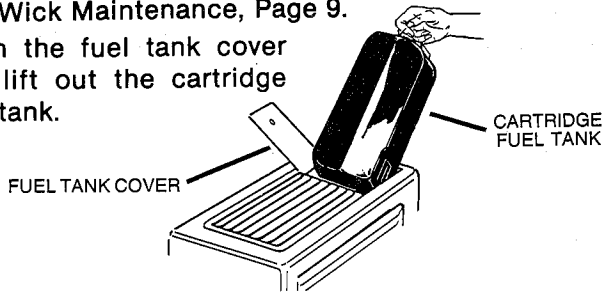

3. Pull the wick adjustment knob towards you and remove.
4. Unscrew the two screws located at each end at the base of the front panel.

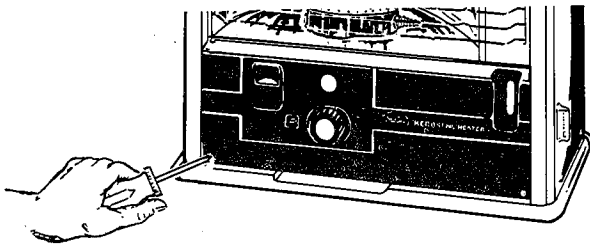

5. Lift away the front panel and safety grill and set aside.

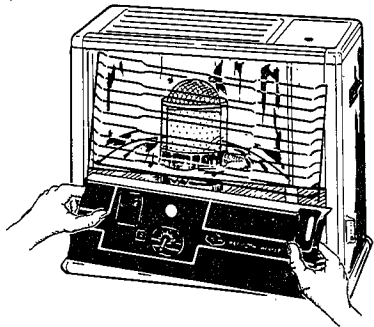

6. Unscrew the two screws located at each end of the burner assembly.

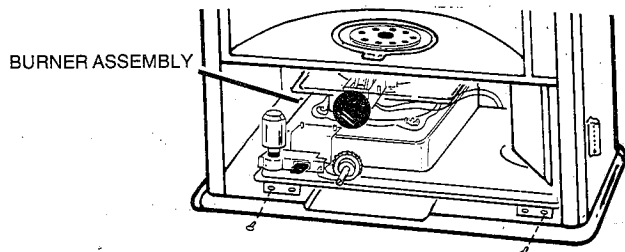

7. Pull the entire burner assembly towards you to remove.

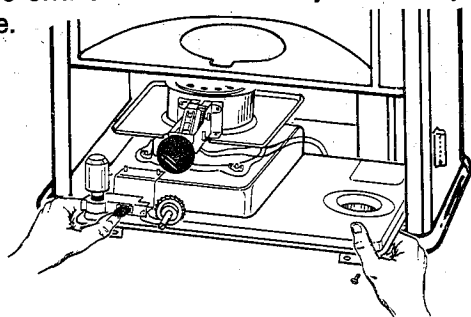

8. Unscrew the wing nut located at the back of the burner and remove the protective plate.
9. Unscrew the four wing nuts located at the bottom of the burner.

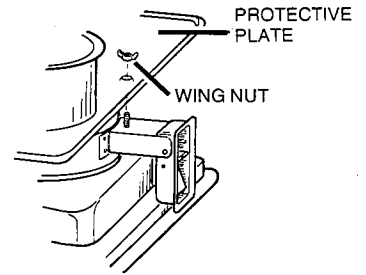

10. Lift the wick housing off the heater base.

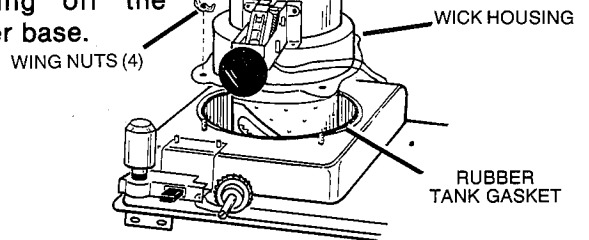

11. It is not necessary to remove the rubber tank gasket.
12. Locate the small retainer clip (hairpin) behind the wick adjustment knob shaft and in front of the wick drive gear.
13. Move the retainer clip (hairpin) until both open ends are facing down. Remove the retainer clip with tweezers or a small screwdriver.

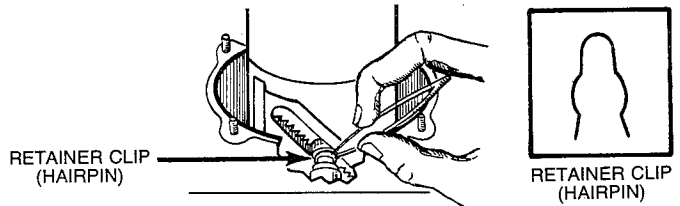

14. Gently pull the wick adjustment knob towards you until the wick drive gear disengages from the wick holder. While the wick drive gear is disengaged, lift the wick holder out of the self-contained fuel tank.

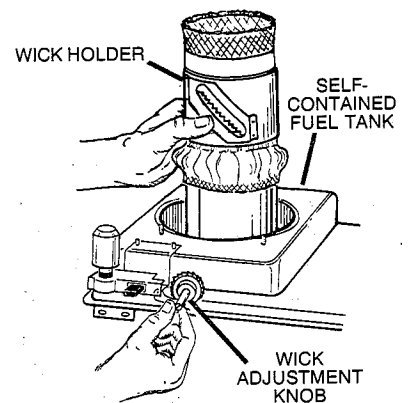

15. Remove the wick from the wick holder by squeezing the top of the wick together. This will release the wick from the holding teeth on the inside of the wick holder.

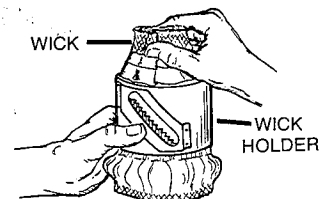

16. Slide the OLD wick out of the wick holder.

## INSTALL NEW WICK

**IMPORTANT:** The Horizontal Line on the New Wick must be positioned properly. Carefully read and follow these instructions.

17. Squeeze the replacement wick and insert it into the bottom of the wick holder. The top of the wick holder is stamped "UP".

A. Position the replacement wick so that the horizontal line of the wick is **EVEN** with the wick holder. Open the wick and firmly, but uniformly, press the wick against the holding teeth around the inside of the wick holder.

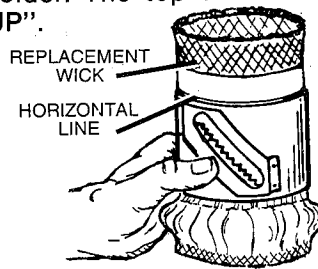

18. Carefully lower the wick holder over the air tube. Make certain that the wick enters the self-contained fuel tank evenly into place. Check to see if the wick is not caught or trapped on the wick adjustment knob gear.

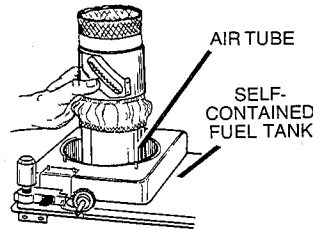

19. Turn the wick adjustment knob clockwise one full turn. (**This method must be followed to engage the Safety Device.**)

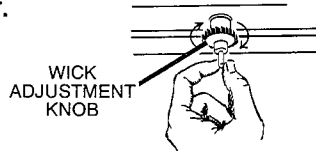

20. Gently pull the wick adjustment knob towards you, then engage the wick drive gear into the top tooth of the wick holder by releasing the wick adjustment knob.

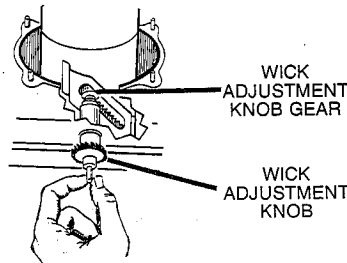

21. Replace the retainer clip (hairpin) behind the wick adjustment knob shaft and in front of the wick drive gear. (The wick adjustment knob will no longer pull towards you.)

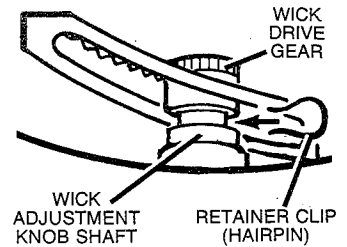

## TO REASSEMBLE YOUR HEATER

22. Turn the wick adjustment knob clockwise until the wick is at its highest level.

23. Carefully replace the wick housing so that none of the wick filaments are bent down.

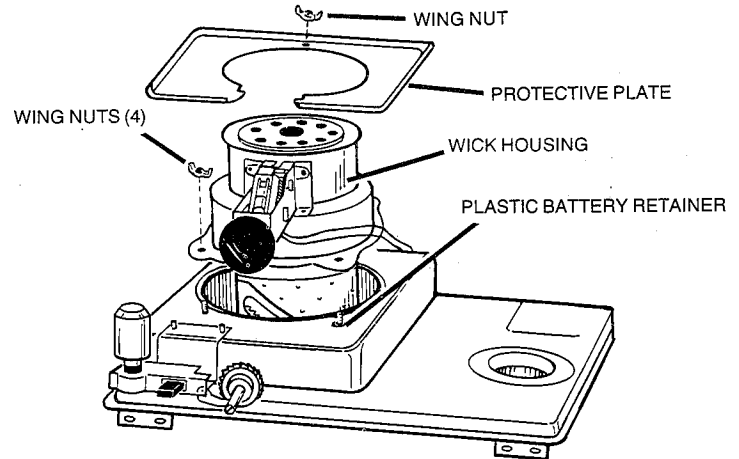

24. Replace the four wing nuts on base of heater. Make certain to place the plastic battery retainer under the right front wing nut.

25. Replace the protective plate and wing nut.

26. Properly insert the burner assembly into the cabinet base.

27. Replace two burner screws.

28. Replace safety grill, front panel and two front panel screws.

29. Replace cartridge fuel tank.

## IGNITION HEATER REPLACEMENT

### REPLACE NEW IGNITION HEATER

1. Disassemble the heater as described in Wick Maintenance, Steps 1, 2 and 3, Page 9.

2. Remove the batteries from battery holder.

3. Press the start button in. Grasp the old ignition heater with your thumb and index finger. Turn the ignition heater slightly counterclockwise and upwards out of the two guide slots to remove.

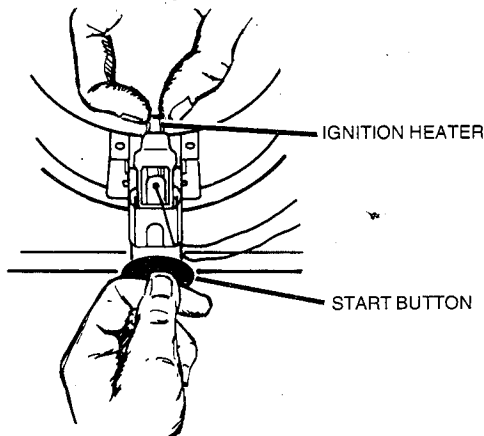

4. Insert the new ignition heater with the filament wire up into the two guide slots and turn slightly clockwise to lock into place.

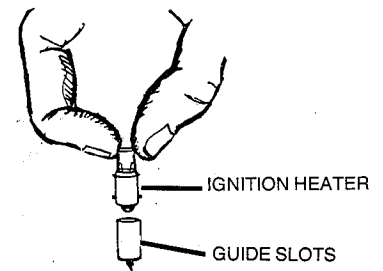

5. Install batteries.

6. Reassemble heater as described in Wick Maintenance, Steps 9, 10 and 11, Page 9.

If the ignition heater still will not light the wick, replace batteries.

Your kerosene heater will give you better service if you replace the ignition heater batteries and wick every heating season.

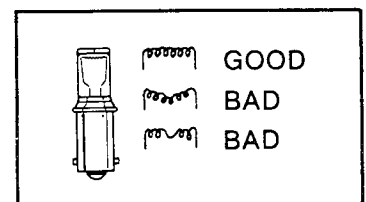

# IN CASE OF AN ACCIDENT

1. If the heater has been tipped over ... the Safety Lever Reset is triggered and the wick is snuffed out. SET THE HEATER UPRIGHT. THEN TURN THE WICK ADJUSTMENT KNOB COUNTERCLOCKWISE UNTIL IT STOPS. MAKE CERTAIN TO THOROUGHLY WIPE UP ANY KEROSENE WHICH MAY HAVE ACCIDENTALLY SPILLED.
2. If the entire heater is enveloped in flames ... SMOTHER FLAMES WITH A FIRE EXTINGUISHER OR SAND. IF NOT AVAILABLE, USE A WATER SOAKED BLANKET. DO NOT THROW WATER DIRECTLY ON THE HEATER. GET PEOPLE AWAY FROM HEATER.

## STORING THE HEATER

1. Syphon out all fuel from tank and close the fuel tank cap tightly.
2. Remove the used wick. A new wick should be used every heating season.
3. Wipe fuel and carbon off the entire heater.
4. Check all nuts, screws and packings for tightness, and the wick adjustment knob for easy movement.
5. Remove batteries when storing the heater.
6. Store the heater in its box in a dry, well ventilated area.

Note: Avoid tilting the heater or laying on its side.

## REPLACEMENT PARTS

Replacement wicks, ignition heaters, and other parts are available from your Authorized Service Stations or:

The Electric Service Station  
P.O. Box 70, Highway 49 North  
Hattiesburg, Mississippi 39401

When writing, indicate that you own a Sunbeam Kerosene Heater, Model 3602.

WHEN SHIPPING YOUR HEATER FOR REPAIR OR SERVICE, EMPTY ALL KEROSENE FUEL FROM THE SELF-CONTAINED FUEL TANK.

## LIMITED ONE YEAR WARRANTY

This product is warranted for one year from the date of purchase against defects in material and workmanship. During this period such defects will be repaired, or the product will be replaced, at NORTHERN ELECTRIC COMPANY'S option, without charge. This shall be buyers sole and exclusive remedy. This warranty does not extend to the following replacement maintenance parts or components: wicks, batteries, and ignitor coils. This warranty does not cover damage caused by misuse or negligence, failure to operate or maintain the heater in accordance with operating and maintenance instructions furnished with each new heater, unreasonable use, accidents, alterations, ordinary wear and tear, the use of unauthorized or nonauthorized parts and accessories, or the use of any fuel other than Water-Clear ASTM D 3699-78 No. 1K Kerosene. ALL IMPLIED WARRANTIES, IF ANY, INCLUDING BUT NOT LIMITED TO WARRANTIES OF MERCHANTABILITY OR FITNESS FOR A PARTICULAR PURPOSE, ARE LIMITED IN DURATION TO THE DURATION OF THIS WRITTEN WARRANTY. NO OTHER WARRANTY, WRITTEN OR VERBAL, IS AUTHORIZED BY NORTHERN ELECTRIC COMPANY. IN NO EVENT SHALL NORTHERN ELECTRIC COMPANY BE RESPONSIBLE FOR LOSS OF USE OF ANY HEATER, LOSS OF TIME, INCONVENIENCE, INJURY TO PERSON OR DAMAGE TO PROPERTY, OR ANY OTHER INCIDENTAL OR CONSEQUENTIAL DAMAGES WITH RESPECT TO BUSINESS OR PROPERTY, WHETHER AS A RESULT OF BREACH OF WARRANTY, NEGLIGENCE OR OTHERWISE. Some states do not allow the exclusion or limitation of incidental or consequential damages or allow limitations on how long an implied warranty lasts, so the above limitations may not apply to you. This warranty gives you specific legal rights, and you also may have other rights which vary from state to state.

Warrantor: NORTHERN ELECTRIC COMPANY  
Division of Sunbeam Corporation

For warranty service, bring the product or send it, postage prepaid to the nearest Authorized Service Station. A list of Authorized Service Stations is included for your convenience. If you send the heater for service, please write a letter explaining the nature of your difficulty to the Service Station.